



MASSEY FERGUSON

100-130 HP

MF TH SERIES TELEHANDLERS

MF TH.6030, MF TH.6534,
MF TH.7030, MF TH.7035, MF TH.7038, MF TH.8043



FROM MASSEY FERGUSON

Contents



Page 04
The New Generation



Page 11
Compact dimensions



Page 12
Manoeuvrability



Page 14
Environment



Page 16
Powerful hydraulics



Page 21
Hydrostatic transmission



Page 22
Servicing

- 03 Massey Ferguson Manufacturing Excellence
- 04 The new generation of agricultural telehandlers
- 06 Choose your maximum capacity depending on your individual needs
- 08 Raising the bar
- 11 Compact dimensions, outstanding manoeuvrability, unbeatable operator comfort
- 12 Maximum productivity, agility and manoeuvrability
- 14 Operator environment – productive, efficient and comfortable
- 16 Powerful and smart hydraulics
- 18 Smart generation of cost effective power
- 21 Smooth operation from the hydrostatic transmission
- 22 Servicing made easy
- 23 MF Services from Massey Ferguson
- 24 Find the perfect attachment for your MF TH Series Telehandler for all your needs
- 26 Specifications

Massey Ferguson Excellence



Anyone who buys an MF Telehandler today will expect it to fulfil the latest operational and environmental standards. They will expect it to combine the very best of today's technologies with comfort, simplicity, reliability and quality day in day out on the farm. Our engineers have farming in their blood and foresight. They are eager to develop new solutions to the complex challenges of today's and tomorrow's farming.

Reliability is in our DNA. We are committed to delivering the highest quality at all times. Each component of the new MF TH Series has been carefully designed, selected and assigned to the best manufacturing supplier and has been assembled following the latest manufacturing technologies.

The new generation of agricultural telehandlers

We are a Global Brand. We are Massey Ferguson. We are committed to farming for more than 170 years, and the new MF TH Series is the telehandler that embodies the full meaning of this statement.

This is a telehandler that embodies all our farming know-how. Because we understand your farm handling needs, we are offering you a true agricultural Telehandler, supported by a true agricultural dealer network to enable you to carry on with the most demanding handling operations such as moving bales, feeding animals or cleaning barns.

Everywhere you look, everything you touch, there is the feeling of high quality. On the bonnet and in the steering wheel you see the logo of a brand that you trust. You are about to put your machine to hard work and will be operating the new MF TH Series for the first time. You don't know how it will be, but you have the feeling that this new telescopic handler won't let you down and will offer you a really high level of performance in all operations.

A vital part of your working day

Our new telehandlers are purpose-built for hard work. Wherever you need a quick, compact solution to many applications, the MF TH Series has the capacity to perform.

- Grab silage and muck, lift bales and fertiliser bags, shift feed and clean sheds
- There are plenty of implements to choose from to accompany your MF Telehandler, including a bale spike, bale squeeze handler, pallet fork and bucket
- Powerful, precise hydraulics allow easy operation of heavy lifting
- Working in tight buildings can often be a challenge. MF TH Series telehandlers are highly manoeuvrable with three steering modes and the option of the TH.6030 and MF TH 7030 semi-compact machine. Get the flexibility you need – including all-round visibility and precision handling
- Minimal servicing required which means hardly any downtime!

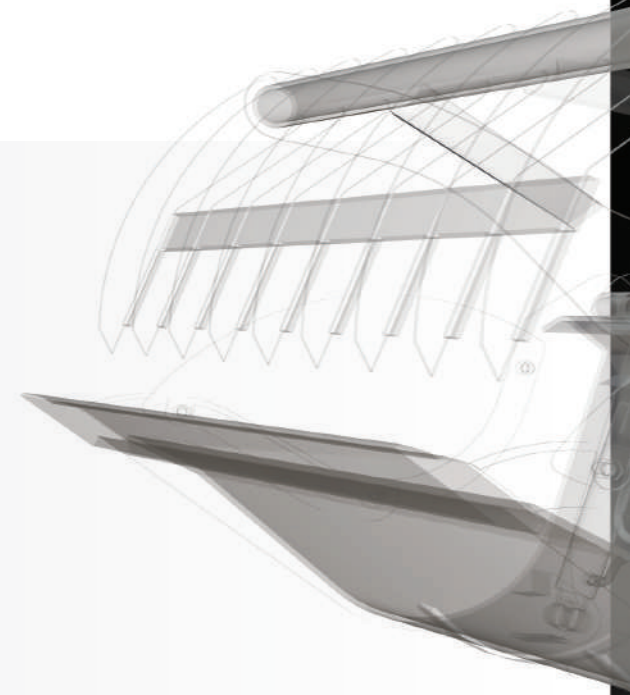

MF TH SERIES TELEHANDLERS



Choose your maximum capacity depending on your individual needs!

MF TH SERIES

Handling jobs effortlessly and efficiently, the new MF TH Series provides any farmer with the optimum accessibility and manoeuvrability required. This new range also gives more lift height, a longer reach and the ability to lift heavier payloads compared to the previous Series. With the right attachment, the MF TH Series can achieve paramount performance in a wide variety of applications around the farm.



MF TH.6030

2.1m x 2.1m semi compact dimensions to easily access the most confined area, 100hp for optimum power to weight ratio, 100 l/min for easy and accurate work



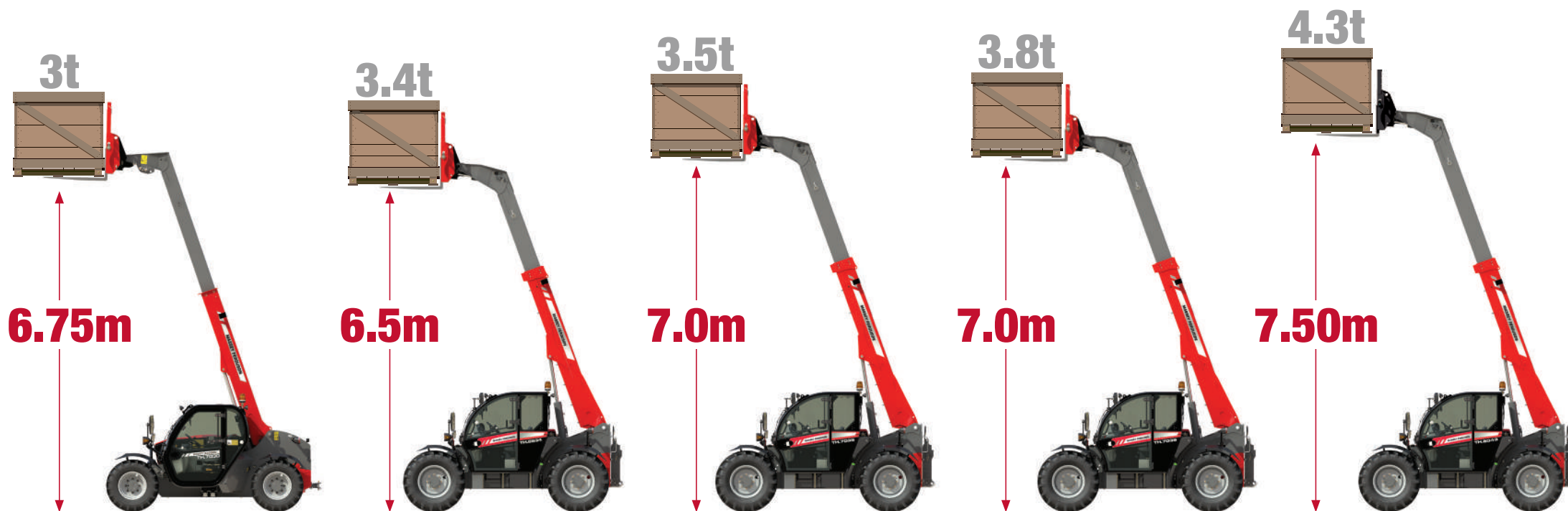

MF TH.7030

2.1m x 2.1m semi compact dimensions to easily access the most confined area, 100hp for optimum power to weight ratio, 100 l/min for easy and accurate work

MF TH.6534

More engine power and oil flow for the most demanding handling and transport applications, 130hp and 190 l/min oil flow for reduced full work cycle

MF TH.7035

The right balance for the most demanding handling applications

MF TH.7038

More engine power and oil flow for the most demanding handling and transport applications, 130hp and 190 l/min oil flow for reduced full work cycle

MF TH.8043

Higher lifting capacities, superior hydraulic performances combined with an optimised hydrostatic transmission and a cabin that offers a superb visibility

Raising the bar

Massey Ferguson's Tier 4 Final TH Series models are now upgraded with a number of new features to further improve productivity, ease of use and efficiency.

Excelling in both loader operations where plenty of hydraulic flow is provided through to 40km/h road transport applications, where power and comfort is essential, each telehandler boasts impressive capabilities, whether you are moving bales or shifting feed. This new range also offers essential and unbeatable visibility thanks to the new cab and the new engine basket design that allows the operator to work unhindered and in complete safety.



HIGHLIGHTS

- 01 **A full selection of attachments available**
to do all the jobs required – see details p.24
- 02 **Quick hydraulic couplers**
for fast, efficient and easy change of equipment with new Electric line on Boom for 4th and 5th electric functions (optional) – see details p.16-17
- 03 **Smart and powerful hydraulics**
All models are fitted as standard with a load sensing valve block. Multiple functions can be done at the same time. Now up to 190l/min CCLS oil flow – see details p.16-17
- 04 **Unbeatable lift capacity**
from the high strength boom – up to 7.50m high and 4,300kg
- 05 **Efficient automatic boom suspension and Cushion Retract**
Boom suspension is available as an option on all models for maximum comfort in transport conditions. Cushion Retract is available as standard on all models for more comfort for the operator allowing the boom to retract smoothly with a reduced/controlled speed
- 06 **Unbeatable comfort and visibility**
The MF TH Series cab environment is equipped/fitted with the highest levels of comfort and controls, with maximum all-round visibility thanks to the curved shape of the cab on the MF TH.6534, MF TH.7035, MF TH.7038 and MF TH.8043 and the new lowest engine bonnet design – see details p.14-15
- 07 **New powerful and fuel efficient engines**
Now up to 130hp for more productivity and performance, Maintenance-Free emission control system and DPF- Free Engine design for less downtime and low cost of operation. Easy access for daily maintenance and an automatic fan inverter option for greater reliability & durability – see details p.18
- 08 **Three semi-automatic selectable steering modes**
to provide optimum manoeuvrability in all operating conditions – see details p.12-13
- 09 **Four-speed (2 mechanical x 2 hydraulic) hydrostatic transmission**
offers simplicity, smooth operation and best in class precision (MF TH.6030 and MF TH.7030 is only fitted with a 2 speed transmission) – see details p.19
- 10 **Automatic Parking Brake**
for increased safety and productivity

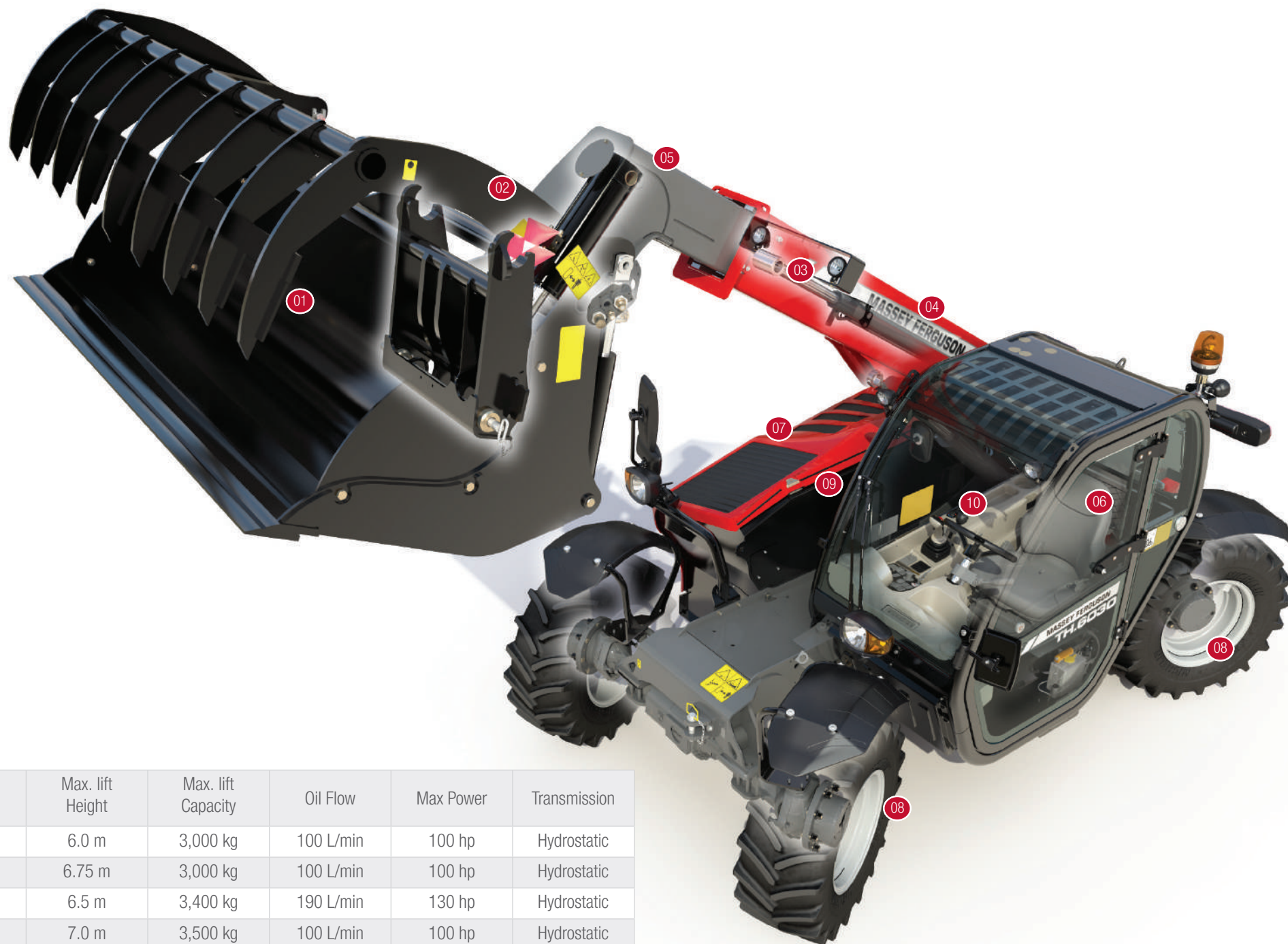

Models	Max. lift Height	Max. lift Capacity	Oil Flow	Max Power	Transmission
MF TH.6030	6.0 m	3,000 kg	100 L/min	100 hp	Hydrostatic
MF TH.7030	6.75 m	3,000 kg	100 L/min	100 hp	Hydrostatic
MF TH.6534	6.5 m	3,400 kg	190 L/min	130 hp	Hydrostatic
MF TH.7035	7.0 m	3,500 kg	100 L/min	100 hp	Hydrostatic
MF TH.7038	7.0 m	3,800 kg	190 L/min	130 hp	Hydrostatic
MF TH.8043	7.5 m	4,300 kg	190 L/min	130 hp	Hydrostatic



MF TH.6030 & MF TH.7030 - Compact dimensions, outstanding manoeuvrability, unbeatable operator comfort

The range starts with the MF TH.6030 semi-compact telehandler. If you are looking for a more compact machine that can still tackle the toughest jobs then the MF TH.6030 and the MF TH.7030 are the ideal choice. Their semi-compact design, two cab positions and excellent manoeuvrability ensure unsurpassed performance in tight areas such as narrow barns and poultry buildings.

Don't be deceived by its size, these telehandlers boast massive lift capacity with the added benefit of being more compact than its bigger counterparts.

Impressive lift capacities in a semi-compact format up to 3 tons and the choice between 6.00m or 6.75m height, making it more than capable of handling many tasks around the farm.



For a smoother operation when retracting the boom, all MF TH are fitted with a dampened retracting system.



Excellent manoeuvrability ensures hassle-free working days for maximum productivity. The spacious cab and comfortable operator area with fully proportional joystick allow for smooth operation.



Two cab positions for maximum versatility including low position for load operation in narrow building. Perfect for jobs where room is limited. The compact design means these models can get in and out of very tight areas without losing visibility and manoeuvrability.



Maximum productivity, agility and manoeuvrability

Every model in the new Massey Ferguson Telehandler line-up is impressive. With engine horsepower up to 130 hp, each one has the power and endurance to tackle the toughest jobs when you need it most. The MF TH Series is a serious performer that will prove to be invaluable around the farm. Speed, agility and strength are just some of the key benefits that make this the ideal multipurpose workmate in all kinds of farming operations.

Handling jobs effortlessly and efficiently, the MF TH Series provides you with the optimum accessibility and manoeuvrability that you require. This range also gives you more lift height, a longer reach and the ability to lift heavier payloads. With the right attachment, the MF TH Series can achieve outstanding performance in a wide variety of applications around the farm.

Excelling in both loader operations, where plenty of hydraulic flow is provided, through to 40km/h* road transport applications, where power and comfort is essential, each MF telehandler boasts impressive capabilities, whether you're moving bales or shifting feed. This new range also offers essential and unbeatable visibility thanks to the new cab design that allows the operator to work unhindered and in complete safety.

*Dependent on market-specific legislation

Boom and chassis design

The new, slender chassis with a shorter overall length ensures stability and excellent manoeuvrability when you need it the most, as well as reassuring durability in the heaviest agricultural operations. A lower boom pivot allows unobstructed visibility around the entire machine, for safer, more productive operation.

Optional boom suspension is available, which greatly increases operator comfort, for example, when towing a large trailer of straw at 40km/h* during road transportation.





Steering functions

All models have three selectable steering modes; two-wheel steer, four-wheel steer and crab-steer to provide optimum manoeuvrability in all operating conditions. Changing from one mode to another is very easy. Just pre-select the mode by pressing the switch in the cab and the mode will be engaged.



Two-wheel steering mode



Four-wheel steering mode
- for minimum turning circles.



Crab-steer mode
- for efficient filling and grading and working alongside walls in confined spaces.

Operator environment – productive, efficient and comfortable

The Massey Ferguson cabins are renowned for excellence, and the MF TH Series follows that legacy. It's something we work hard for, so you can sit and reap the benefits when days are long, in a very productive environment that blends comfort and quietness, with ease of use and quality. We know that a more productive operator will create more profit for his business.

The new, curved shape cab design, the new engine bonnet lower profile and the low boom pivot point ensures unsurpassed visibility all around the machine, especially from the rear of the cab whilst working in tight and narrow spaces. An unobstructed view of front attachments ensures safe and precise loading and unloading, making it easier and safer to position bales or pallets at elevated working heights.



Working LED lights

Increased visibility in all light conditions with optional road and working LED lights

Intuitive controls thanks to the Multifunction Joystick

The new multifunction joystick is close to hand, ensuring efficiency, quick and easy operation and total productivity. A digital display screen located on the dashboard shows valuable information such as maximum speed and flow of hydraulics, job hours, vehicle or engine speed, boom angle, speed management and auxiliary hydraulics.

The positioning of the joystick falls naturally to hand and incorporates all the main controls needed for operating the boom and attachments.

- 01 & 02 Dashboard display settings
- 03 Boom extended/retracted
- 04 3rd function
- 05 Boom suspension
- 06 Optional forward, neutral, reverse selection



Standard feature Eco mode

The operator can activate a new eco-mode by just the flick of a switch in the cabin. Oil flow and engine RPM are managed in order to reduce fuel consumption.





An Operator area to increase Comfort

The superior operator environment consists of a spacious cab interior with excellent all-round operator visibility and a reduced noise level. The cab layout is extremely ergonomic; controls and instruments are easy to use and have been designed to help make applications easier to manage.

Powerful and smart hydraulics

A powerful and consistent hydraulic system is paramount to the everyday productivity of a telehandler. There is a load-sensing spool valve management system on all models.

All functions are electro-hydraulic and proportional thanks to a load-sensing hydraulic system. It's very accurate and easy to use, plus it allows the operator to simultaneously use three functions, increasing productivity and reducing downtime.

There is optimum hydraulic flow across the entire range with 100L/min on MF TH.6030, MF TH.7030 and MF TH.7035 models and a market-leading flow of 190 l/min on the MF TH.6534, MF TH.7038 and MF TH.8043.

The load-sensing pump that supplies 190 litres of oil per minute on the MF TH.6534, MF TH.7038 and MF TH.8043, offers outstanding capabilities and performance, even at low engine speeds. Therefore, you can work at significantly lower engine speeds, consume less fuel and can count on remarkably shorter working cycles. The load sensing pump only supplies oil when hydraulic power is required. This prevents unnecessary oil-heating and power loss. If required, the full oil volume is available immediately.



SMART HANDLING

High spec boom controls, thanks to 4 electro hydraulic load sensing spool valves, will allow the operator to simultaneously use 3 functions with high precision. The oil goes exactly where the operator wants it to go, it does not simply go where it's easy. Optional boom suspension also provides outstanding comfort for all transport applications. Its activation is automatically linked to the speed of the machine.

"Standard feature SHS (smart handling system). From the new display menu, the operator will be able to set the max hydraulic flow available. By adjusting the max flow, the machine can be much smoother and more accurate.



Integrated, pressure-release quick couplers are conveniently mounted on the boom head for fast, efficient and easy coupling and uncoupling of implements.

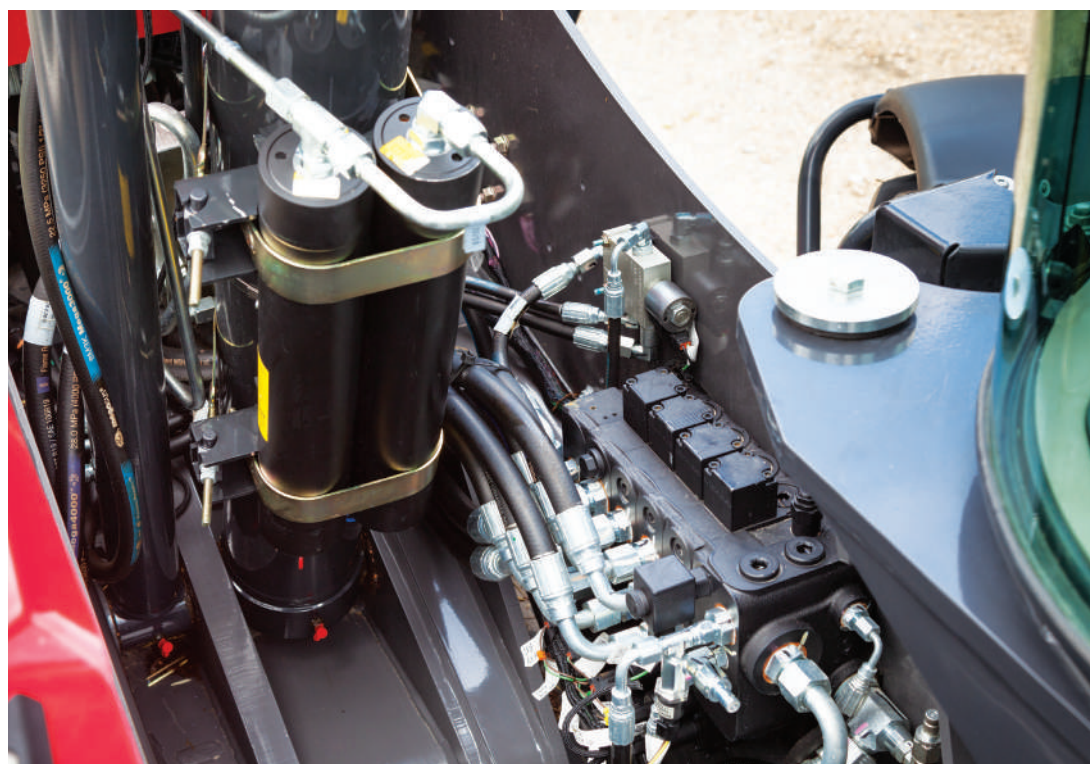

Connecting and disconnecting is simple thanks to the connector block and its pressure release system. For more demanding implements such as straw choppers and feeding buckets an electric line can be specified, giving a fourth and fifth service.

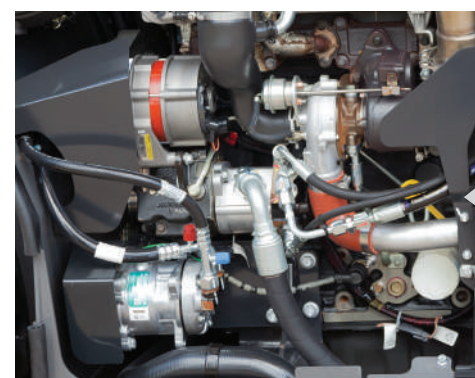

A load sensing pump on the MF TH.6534, MF TH.7038 and MF TH.8043 models supplies a class-leading 190 litres of oil per minute.

Smart generation of cost effective power

Thoughtful engineering and design means that you receive the best features within the MF TH Series telehandler. Powerful, efficient engines, high-performance transmissions and precision hydraulics, guarantee a trustworthy ally for many of the jobs you need to get done quickly on the farm. The MF TH Series features a new 3.6L four-cylinder Tier 4 Final compliant Doosan engine which uses straightforward technology to give an environmentally friendly solution with no compromise. The engine delivers 100hp on the MF TH.6030, MF TH.7030 and MF TH.7035 and 130hp on the MF TH.6534, MF TH.7038 and MF TH.8043.

Each of these models has a powerful and efficient engine, providing plenty of torque in applications that demand more traction and force. The larger and improved design of the engine cooling system ensures continuously high performance in demanding and confined operations. The engine is mounted lengthways, not only does this ensure space for the boom to sit without impeding visibility when in the cab, but access to the engine area for servicing and maintenance is easy and straightforward.

Automatic fan Inverter

A proven feature from the previous MF Telehandler generation is now available with an automatic option to keep the engine clean for maximum efficiency. It offers speed regulation depending on air temperature or working at a pre-set speed, with automatic mode selected via a button on the dashboard.



Standard feature ECO mode

The operator can activate a new ECO mode by just the flick of a switch in the cabin. Oil flow and engine RPM are managed in order to reduce fuel consumption.

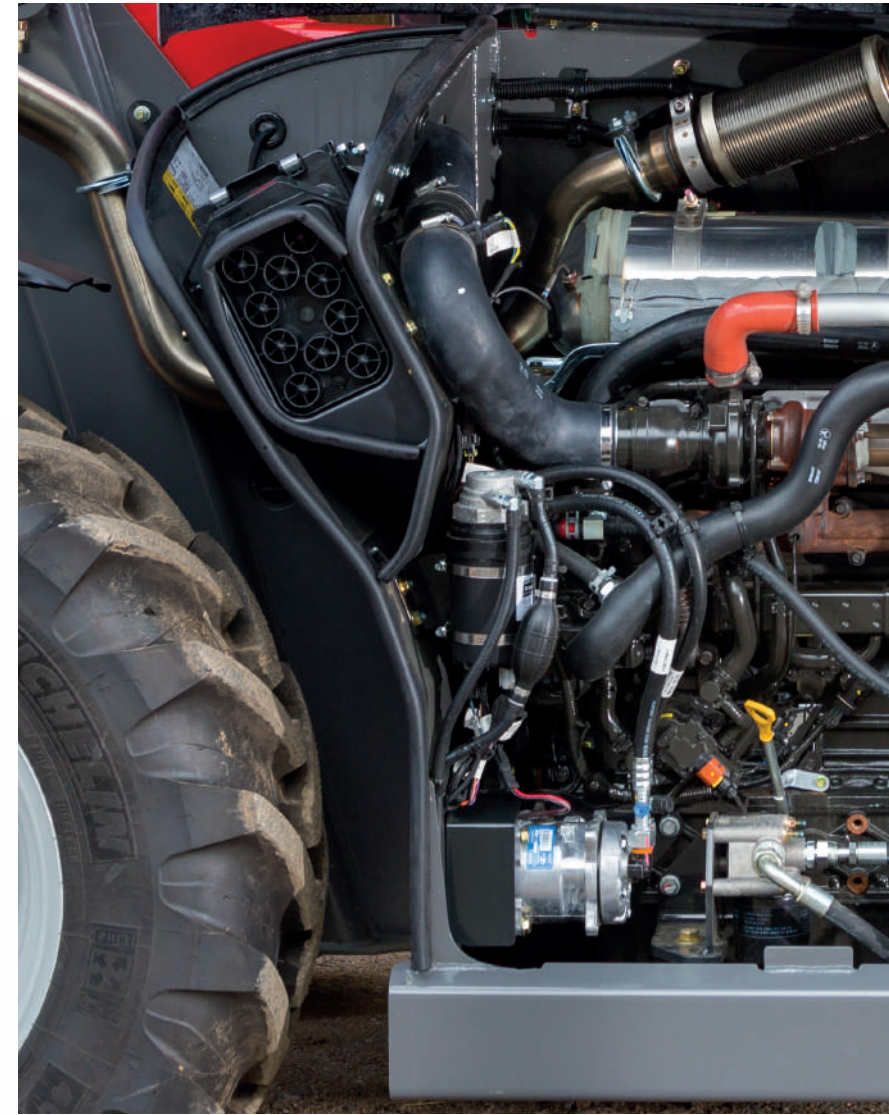



A new engine installation and basket design has lowered the height of the engine for improved right hand side visibility. With a reinforced bonnet and bigger opening, MF TH models also benefit from a new bonnet opening handle system

ENGINE HIGHLIGHTS

- Maintenance-free emission control system, high performance engine.
- Powerful and efficient with ECO Mode
- Low operation costs courtesy of a DPF and EGR free engine design saves time and money
- The engine remains parallel to the boom, providing excellent access for inspection of the engine bay area and improved right-hand side visibility
- Straightforward technology for a more productive working day
- Optional automatic fan inverter for easy cooling package cleaning and optimum productivity



Smooth operation from the hydrostatic transmission

The two speed hydrostatic gearbox offers simplicity and smoothness of operation as well as high-performance output and capability. It has speed capabilities of up to 40km/h* with two mechanical gears with two hydraulic speed ranges which allows the customer to choose the best speed for the application and gives excellent performance in road transport.

It also has an easy-to-set creeper function for operations that demand low speed at higher engine revs. This feature provides more accuracy and control for operation such as sweeping, silage distribution, and straw spreading.



TRANSMISSION HIGHLIGHTS

- Hydrostatic transmission allows very accurate and very smooth control
- Unique 4 speed transmission providing high power and high performance
- Choose the best ratios for ergonomic control of the machine
- Maximum speed can be set thanks to creeper mode. This is perfect for silage distribution

*Dependent on market-specific legislation

Side opening of the bonnet gives you wide, open access to the engine, air filter, cooling system and air conditioning system, providing quick serviceability to all the major points.



The air filter is removed easily for checking and cleaning. An optional automatic reverse fan is available if required. Just press the switch or set the automatic activation and the fan reverses its cycle, blowing out any dust, straw and other material that may become stuck to the cooling package.



From ground level, you can easily lift the hood to check the engine and radiator. All routine engine, hydraulic and transmission service points are easily located for fast and simple maintenance, keeping downtime to a minimum.



Servicing made easy

Less downtime - more work done

Fast, straightforward and easy routine maintenance thanks to the parallel engine installation. Servicing is straightforward and simple thanks to well positioned service points, taking the stress out of maintaining your telehandler and leaving you with more time in the field/at work.



Easy to fill diesel and AdBlue® tanks from ground level.

MFservices

Combined services to increase our customers' profit and efficiency

Welcome to MF Services – everything you need to support the operation of your Massey Ferguson machine.

Accessible and adaptable, MF Services will help you control running costs, budgeting and business planning - ensuring each machine operating hour is a success and giving you the freedom to focus fully on the core business of farming.

This comprehensive suite of service-related-products makes it easier than ever to own and operate MF farm equipment.

Covering finance, extended warranties and servicing, telematics, precision farming technologies and genuine parts, MF Services is your one-stop shop for all existing and future services to keep your business on track and your equipment up and running.

Our goal is to ensure that your Massey Ferguson machinery is operationally-efficient at the highest level throughout its working life.

MFCare provides total peace of mind

MFCare Service and Extended Warranty Plan* is a comprehensive, industry-leading package that provides total care of your machine providing routine maintenance, repairs and a full AGCO-backed warranty, which includes:

- Engine and transmission
- Electronics
- Hydraulics
- Cab and controls
- Steering
- Axles

Regular servicing in the **MFCare** plan provides 'preventive maintenance' – picking up any faults before they become a problem, which helps reduce downtime. A full dealer service history, using genuine AGCO Parts will also increase the residual value of the machine.

AGCO Finance* provides the perfect financing arrangement for your business

AGCO Finance is the integrated financial services arm of Massey Ferguson offering tailor made solution to your own farm, which includes :

- Leasing
- Loan facilities
- Hire purchase
- Full service packages
- Contract hire

* Please contact your Massey Ferguson local dealer to check availability in your area. Terms and conditions apply that might vary according the market or country.



Industry-leading parts supply from AGCO Parts.

Find the perfect attachment for your MF TH Series Telehandler for all your needs

We offer the perfect range of attachments to go with the MF TH Telehandler Series (purposely engineered and built of the MF TH Series) to be able to cope with all type of applications: lifting light or heavy loads, move silage, feeding livestock, etc...

Bucket, Digging and Loading

Tackle the toughest digging and material handling tasks with our robust digging and loading buckets. They offer good visibility of the cutting edge, excellent breakout force for digging and easier and faster bucket filling. Available in a range of capacities, with or without teeth.

Bucket, Large Capacity

Boosts productivity thanks to its increased roll-back angle to minimize spillage. Use it to load grain to trucks or to distribute fertiliser.

Bucket with Grapple

The ideal attachment to pick up and handle dirt and soil with overgrowth, branches or other bulky materials that need to be firmly grasped during transport.

Fork with Grapple

This is the easy way to handle loose hay, bedding and manure on the farm and other sites. Use the utility fork by itself or add the hydraulic grapple for more gripping power.

Pallet Forks

Great for handling bulky or bagged materials such as fertilizer, seed and animal feed. Especially handy when you're working in tight areas. Choice of rigid or floating forks available (with sideshift on the rigid fork frame).

Bale Fork

Use it to efficiently transport and load round bales from the ground onto a trailer or into a bale feeder.

Bale Squeeze Handler with Tubes

All the performance of our tined bale handler but with two hydraulic arms in the form of round tubes to ensure a secure hold on single bales.

Bale Squeeze Handler with Tines

Transport and load up to two round bales from the ground to a trailer or bale feeder. The independent hydraulic arms, each equipped with 4 tines, provide a firm grip.



Lift capabilities

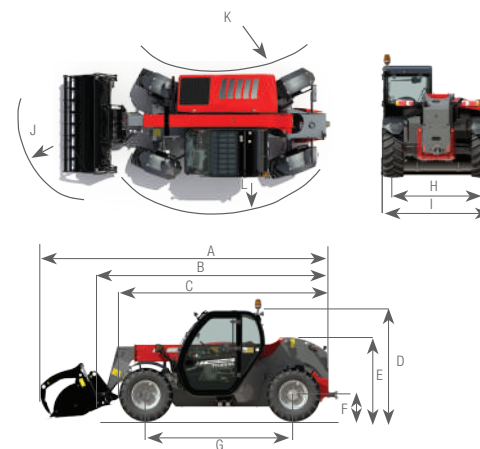
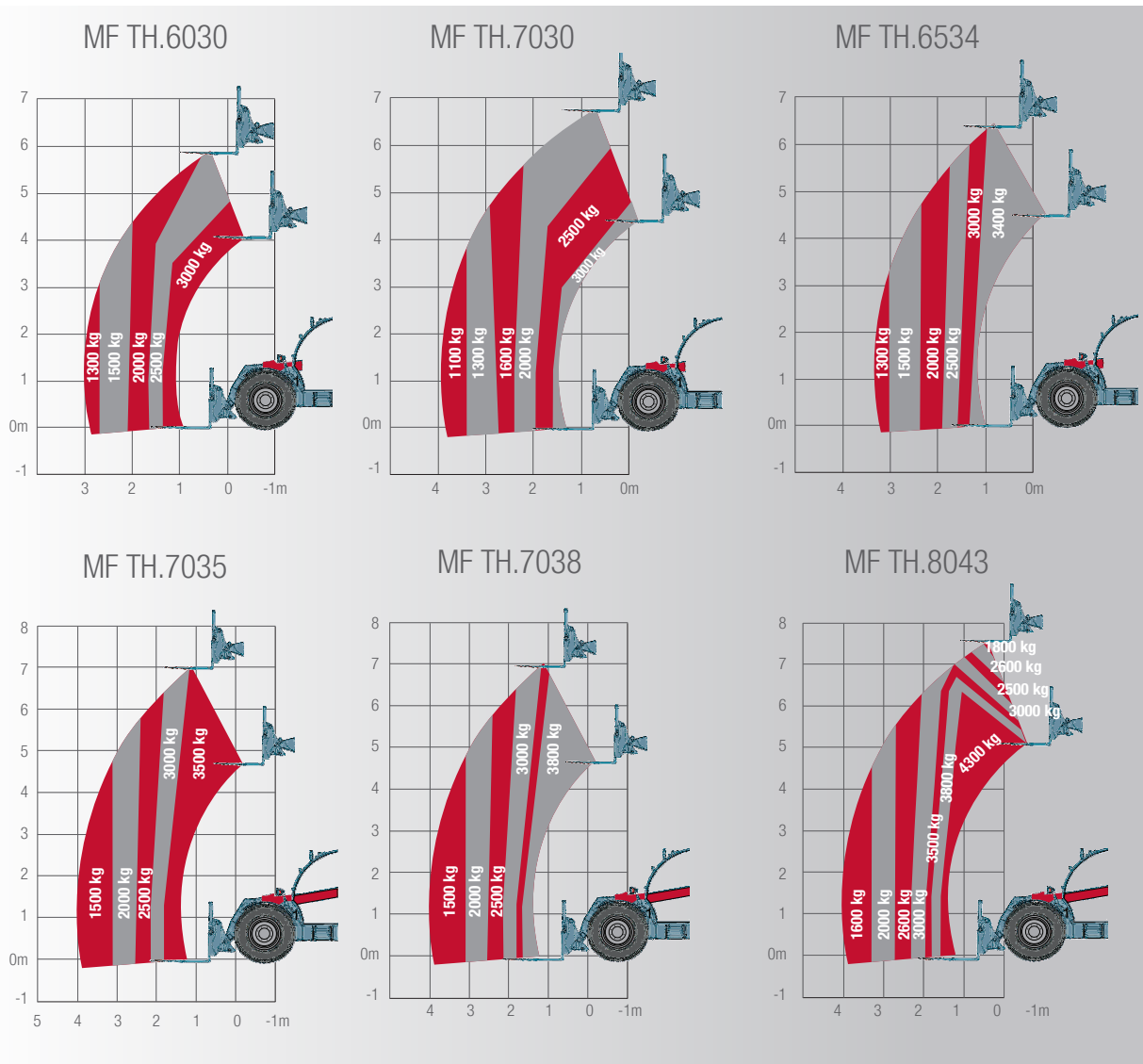

		MF TH.6030 Std cab	MF TH.6030 low position cab	MF TH.7030 Std cab	MF TH.7030 low position cab	MF TH.6534	MF TH.7035 MF TH.7038	MF TH.8043
A	mm	5712 ¹		6278 ¹		5874	6074	6180
B	mm	4507		5063		4669	4869	4975
C	mm	4123* 4035**	4123* 4035**	4123* 4035**	4123* 4035**	4145	4145	4246
D	mm	2334* 2250**	2184* 2100**	2334* 2250**	2184* 2100**	2374	2374	2374
E	mm	1671* 1587**	1671* 1587**	1671* 1587**	1671* 1587**	1752	1752	1770
F	mm	348* 264**	348* 264**	348* 264**	348* 264**	430	430	430
G	mm	2820	2820	2820	2820	2870	2870	2870
H	mm	1666		1666		1895	1895	1895
I	mm	2100		2100		2300	2300	2300
J	mm	4922* 4812**		4922* 4812**		4805	4970	4995
K	mm	1329* 1503**		1329* 1503**		1161 - 1631		
L	mm	3717* 3875**		3717* 3875**		3714 - 4192		

*24" tyres ** 20" tyres ¹with pallet forks

These load capacity illustrations clearly show that each model offers outstanding lift performance in its respective class.

Specifications as standard

Loader performance (norm EN 1459: 1998 Annex B)	MF TH.6030	MF TH.7030	MF TH.6534	MF TH.7035	MF TH.7038	MF TH.8043
Max. lift capacity						
at ground level kg	3,000	3,000	3,400	3,500	3,800	4,300
at full lift height kg	2,500	2,000	3,400	3,500	3,800	2,600
at load configuration 2m length @ 4 m height kg	2,000	2,000	3000	3,000	3,000	3,000
Breakout force kN	3,600	3,600	6,200	6,200	6,200	7,000
Max. lift height m	5.8	6.70	6.5	7	7	7.5
Forward reach - boom extended m	3.13	3.9	3.4	4	4	4.1
Hydraulic system						
Boom - gear pump capacity litre/min	100	100	190	100	190	190
Transmission						
Type	Hydrostatic					
Mechanical gears	2	2	2	2	2	2
Hydraulic speeds	2	2	2	2	2	2
1st gear speed* km/h	9.7	9.7	6	6	6	6
2nd gear speed* km/h	40	40	12	12	12	12
3rd gear speed* km/h	-	-	18	18	18	18
4th gear speed* km/h	-	-	40	40	40	40
Engine						
Capacity/no. cylinders /no. litres	3.4/4	3.4/4	3.4/4	3.4/4	3.4/4	3.4/4
Injection	Common rail	Common rail	Common rail	Common rail	Common rail	Common rail
ISO hp @ 2400 rev/min	100	100	130	100	130	130
Max. torque (ISO 14396) Nm	430	430	500	430	500	500
Fuel tank capacity	115	115	138	138	138	138
Tyres						
Standard	405/70 20	405/70 20	400/80R24	400/80R24	400/80R24	400/80R24
Optional	400/70R24	400/70R24	500/70R24	500/70R24	500/70R24	500/70R24
Brakes	Oil immersed					
Weights and capacities						
Weight, without implement kg	5200	5600	6500	7130	7130	8040

* with max speed specified machine

Standard and optional equipment by version

	MF TH.6030	MF TH.7030	MF TH.6534	MF TH.7035	MF TH.7038	MF TH.8043
Hydraulics						
All hydraulic function proportional and electro hydraulics	●	●	●	●	●	●
Boom 3rd function with adjustable Flow	●	●	●	●	●	●
Mechanical implement attachment	●	●	●	●	●	●
Cushion retract	●	●	●	●	●	●
Smart Handling System (SHS)	●	●	●	●	●	●
Transmission						
Hydrostatic (40 Km/h)	●	●	●	●	●	●
Inching pedal	●	●	●	●	●	●
Speed Control System	●	●	●	●	●	●
Electric Parking Brake	●	●	●	●	●	●
Engine						
ECO Mode	●	●	●	●	●	●
Automatic isolator switch	●	●	●	●	●	●
Integrated Cyclonic air pre-filter	●	●	●	●	●	●
Cab						
Air pneumatic seat	●	●	●	●	●	●
Working lights	●	●	●	●	●	●
Aerial speakers & antenna	●	●	●	●	●	●
Rotating beacon & Back Up alarm	●	●	●	●	●	●
Roof wiper	●	●	●	●	●	●
Steering						
Three steering modes with automatic alignment	●	●	●	●	●	●
Front axle with differential @ 45% limited slip	-	-	●	●	●	●
Bucket						
Pin Bucket support	●	●	●	●	●	●

	MF TH.6030	MF TH.7030	MF TH.6534	MF TH.7035	MF TH.7038	MF TH.8043
Forward/Neutral/Reverse control on joystick	○	○	○	○	○	○
Forward/Neutral/Reverse control: Left & Joystick	○	○	○	○	○	○
Automatic reverse fan	○	○	●	○	●	●
Hydraulic implement attachment	○	○	○	○	○	○
Automatic boom suspension	○	○	○	○	○	○
Boom head 4th & 5th functions	○	○	○	○	○	○
Trailer brake	○	○	○	○	○	○
Hitch: Hydraulic hook / height adj. clevis	○	○	○	○	○	○
Rear hydraulic spool valve	○	○	○	○	○	○
Air conditioning	○	○	○	○	○	○
High comfort seat	○	○	○	○	○	○
Work lights on boom	○	○	○	○	○	○
Work lights for henhouse	○	○	○	○	○	○
Road LED lights (Only right hand side driving)	○	○	○	○	○	○
Work LED lights	○	○	○	○	○	○
Tool box	○	○	○	○	○	○
Implements						
Digging bucket	○	○	○	○	○	○
Light material bucket	○	○	○	○	○	○
Pallet fork	○	○	○	○	○	○
Bale spike	○	○	○	○	○	○
Grapple bucket	○	○	○	○	○	○
Grapple fork	○	○	○	○	○	○
Bale handler (teeth or tube)	○	○	○	○	○	○

- Not available
- Standard specification
- Optional

Every effort has been made to ensure that the information contained in this publication is as accurate and current as possible. However, inaccuracies, errors or omissions may occur and details of the specifications may be changed at any time without notice. Therefore, all specifications should be confirmed with your Massey Ferguson Dealer or Distributor prior to any purchase.



MASSEY FERGUSON

A world of experience. Working with you.



Web: www.MasseyFerguson.com

Facebook: www.Facebook.com/MasseyFergusonGlobal

Twitter: Twitter.com/MF_EAME

Instagram: Instagram.com/MasseyFergusonGlobal

YouTube: www.YouTube.com/MasseyFergusonGlobal

Blog: Blog.MasseyFerguson.com



MASSEY FERGUSON is a worldwide brand of AGCO.
© AGCO Limited. 2019 | A-A-16609 | English/0319



Responsible forest management

